

TactPlus.™

User Manual



Everything you can imagine is
Real

INTRODUCTION

Thank you for buying our TactPlus. printer.

This printer can produce both braille and tactile image at the same time unless this is something the customer has to do, eliminate it.

Name of "TactPlus" is overseas edition of EasyTactix made by SINKA Corporation. Read carefully this manual before using this product.

Quick start guide meaning of symbols

<p>Please understand the meaning of symbols before you read this manual.</p>	<p>prohibited operation</p>  <p>【prohibited】</p>	<p>Hazardous situation</p>  <p>【caution】</p>
--	---	---

- * Reprinting of part or the whole of the contents of this document is strictly forbidden.
- * The contents of this book are subject to change without notice in matters of improved function.
- * We are not responsible for taking this product out of the country.

Trademark

- * All named products and descriptions are trademarks and/or registered trademarks of the respective manufacturers and are accepted as protected.
 - * Microsoft, windows, Aero, Windows Live, Access, Excell, Excell logo, office logo, OneNote, Outlook, PowerPoint, Windows Media, Windows logo, and Windows start are registered trademark by Microsoft USA or related company.
- TactPlus.TM is registered trademark of Kanematsu Corporation and is accepted as protected.

Contact and Inquiry Kanematsu Corporation

1-2-1, Shibaura, Minatoku, Tokyo, Japan

NORTH & SOUTH AMERICA	TEL : +1 - 732 - 271 - 7561
EUROPE(incl. Middle East, Africa)	TEL : +49 - 211 - 3689 - 234
South East Asia (incl. India, Oceania)	TEL : +66 -2 - 632 - 8077
Other Region	TEL : +81- 3 - 5440 - 8468

INDEX

■ Chap.1 Outline of TactPlus.	5
① Name and function of each item	5
② Rear View	6
③ Accessories	6
④ Power/Message Lamp	7
⑤ Voice Guidance	7
⑥ Dedicated Paper	7
■ Chap.2 Installation	8
① Space for installation	8
② Operating conditions	8
③ Note	8
■ Chap.3 How to connect	9
① Caution (Installation)	9
② Inserting the Power code	9
③ Connection with USB cable and PC	9
■ Chap.4 USB printer driver installation	10
① Related Software Installation	10
② Installation procedure for Printer Driver with USB	10
③ Installation of Printer Driver with USB	11
④ Uninstallation of Printer Driver	12
⑤ Delete setup application	13
■ chap.5 How to connect with Wired LAN / Wi-Fi	14
① How to connect with Wired LAN	14
② How to connect with Wi-Fi	15
③ Add Wi-Fi mode	17

■ Chap.6 Add the second Printer	18
① Add the second Printer	18
■ Chap.7 Set Dedicated Swell paper	19
① Set Dedicated Swell paper	19
■ Chap.8 How to Print	20
■ Chap.9 Printer Driver Specification	21
● How to open Properties	22
■ Chap.10 Voice Guidance and Message on Display	23
■ Chap.11 Power / Message Lamp	25
■ Chap.12 FAQ	26
● Printer is not turned on.	26
● Printer is working, but print preparation is not complete.	26
● Printer is ready, but print won' t start after sending data.	26
● Printer is working, but paper is not foamed.	26
● Paper is foamed, but too low/tall/ rough.	26
● Would like to adjust volume of Voice Guidance	26
● Paper is jammed.	26
● Paper is not fed properly.	27
● Other Troubles.	27
■ Chap.13 Product Specification	28
■ Chap.14 Registered Trademark & Description	29
■ Chap.15 Service support/ Purchase of dedicated paper / Manufacturer	29
■ Chap.16 Operation Manual Revision history	29

Chap.1 Outline of TactPlus.

① Name and function of each item

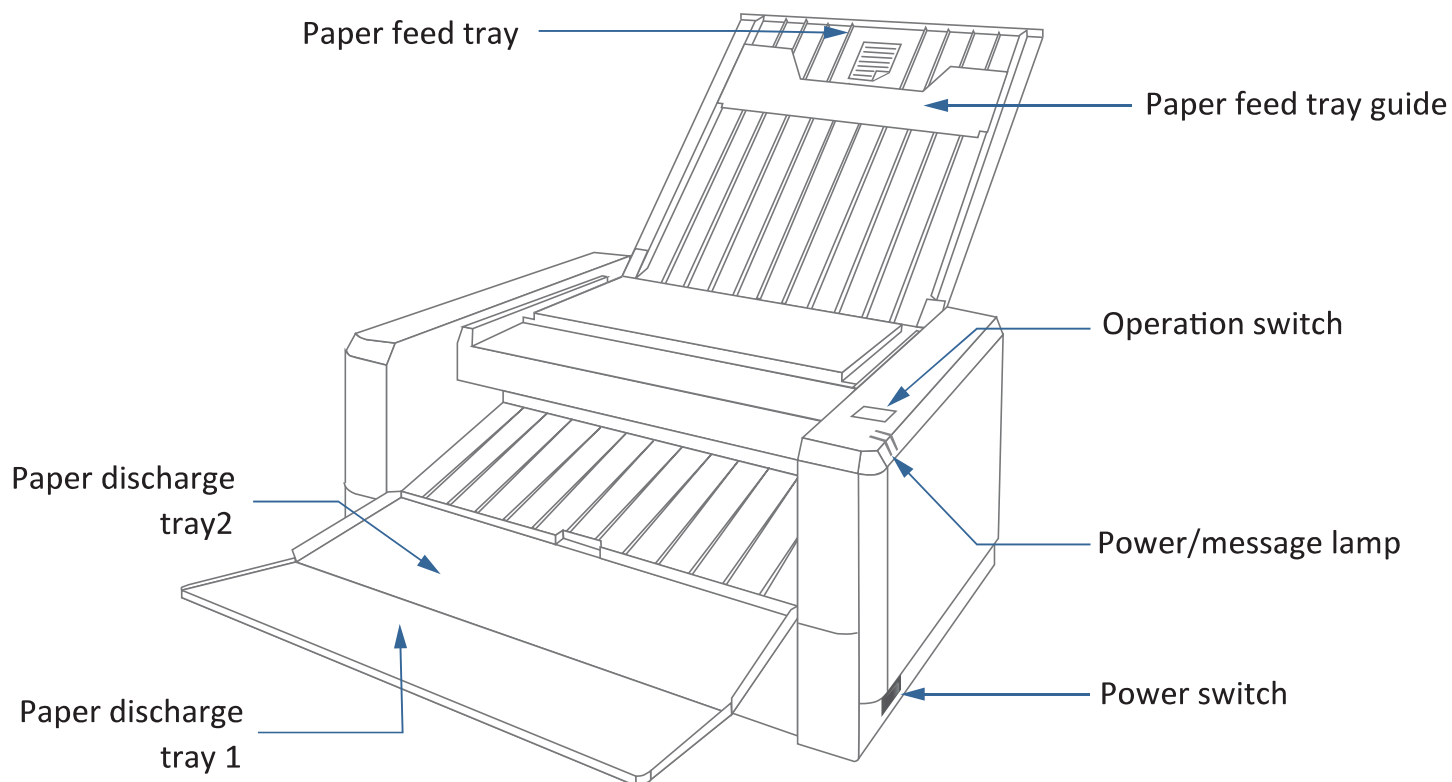

Paper feed tray

Paper feed tray for printing.

Paper feed tray guide

Hold a sheet before printing.

Paper discharge tray 1/2

Receive the sheet after printing.

Power/message lamp

Display the machine status with two LED lamps.

Power switch

When the power is turning on,
switch is placed on rear side.

When the power is turning off,
switch is placed on front side.

2 Rear View

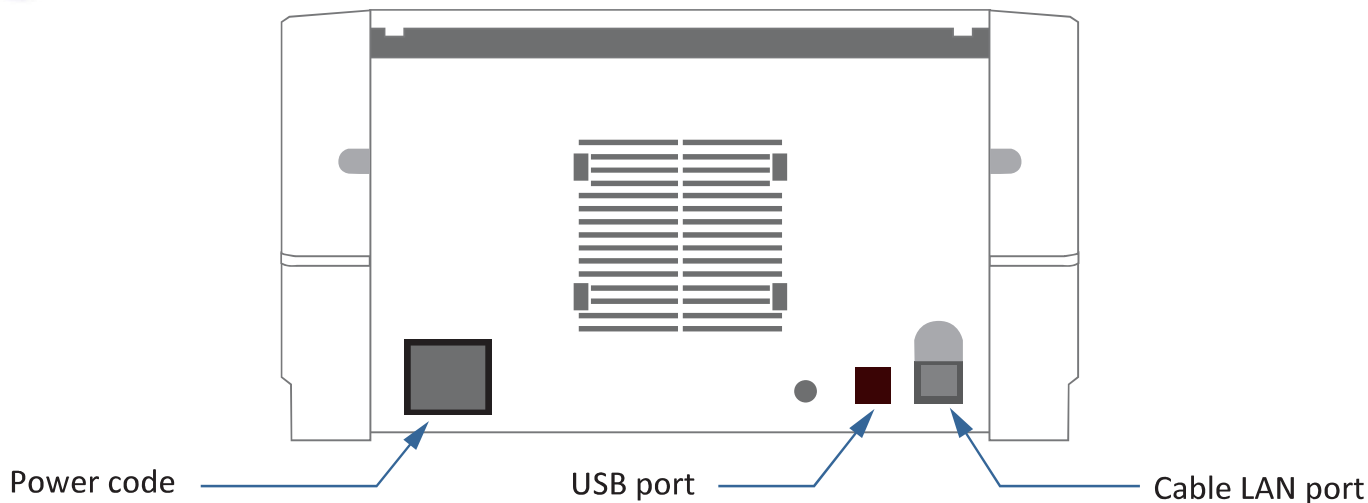

Power code
Connect the power code and cable.

USB port
Port for connecting PC and printer.

USB LAN port
Port for connecting PC and Cable LAN.

3 Accessories

(Please first check the box contents according to the following illustrations.)

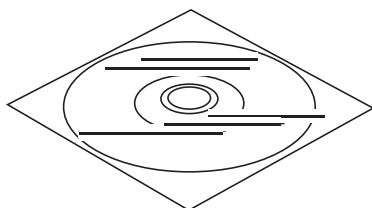

CD-ROM
(USB printer driver/
Addin software for Microsoft
WORD® & Excel®/
operation manual)



Quick start guide

4 Power/Message Lamp

This machine displays status with two lamp colors.
For details, see the P23. “Power / Message Lamp Description” .

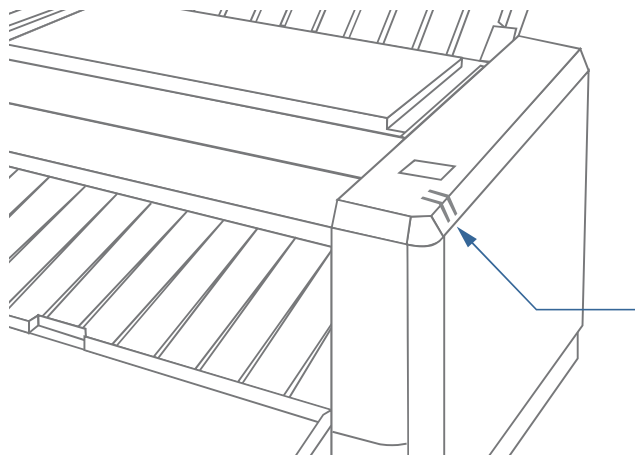

5 Voice Guidance

Audio guide is built-in this machine.
For details about sound guidance, see the P. “Audio guide” .

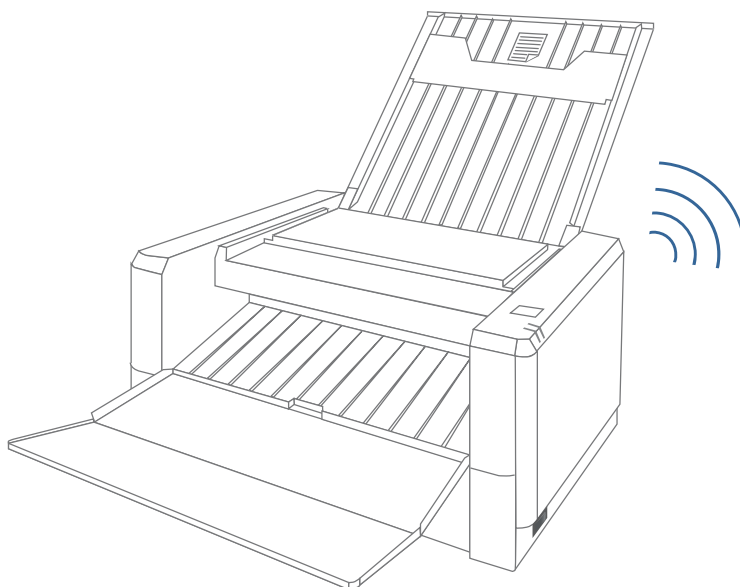

6 Dedicated Paper



Use the genuine three-dimension sheet only,
because other sheets may cause trouble.

Chap.2 Installation

1 Space for installation



【caution】

Install this machine in the location which satisfies the following conditions :

- *Area with no direct sunlight and not dusty.
- *Area of low humidity and not exposed to the spilled liquid such as water, oil and chemicals.
- *Aread distant from any magnetism or radio wave generating equipment such as TV and wireless system.
- *Level, solid and stable area
- *The gap of 10 centimeter or more shall be set around the machine.

2 Operating conditions

Operating Temperature: 10~30°C Operating Humidity : 35~70%RH(NO CONDENSATION)

3 Note



【caution】

- ◆ carry carefully so as not to cause falling or hurting.
The body weight is 4.9kg.
- ◆ Carry roughly or shaking will be the cause of trouble.

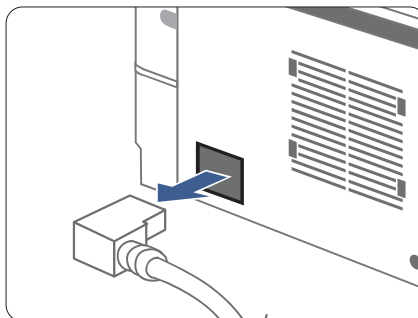
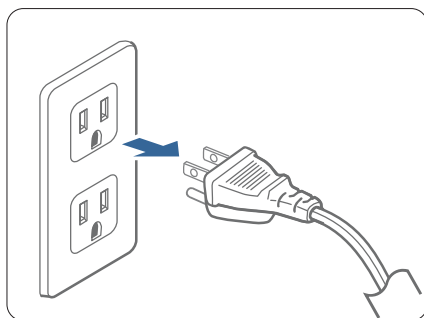

- ◆ Turn off, plug out the power cable and take off cable before carrying.
- ◆ Do not pull the cable harder but pull the power plug when you pull the cable.

Chap.3 How to connect

1 Caution (Installation)



[caution]

All the connection has to be done after verifying that the power switch is turned OFF.

2 Inserting the Power code

Verify that the power switch is turned off then insert the power code to the power outlet.

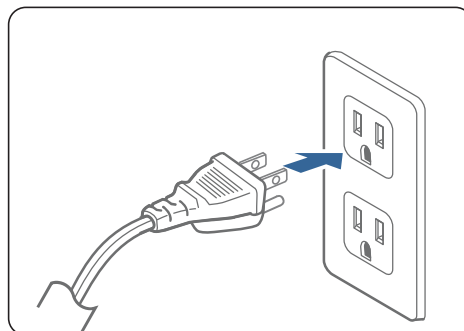
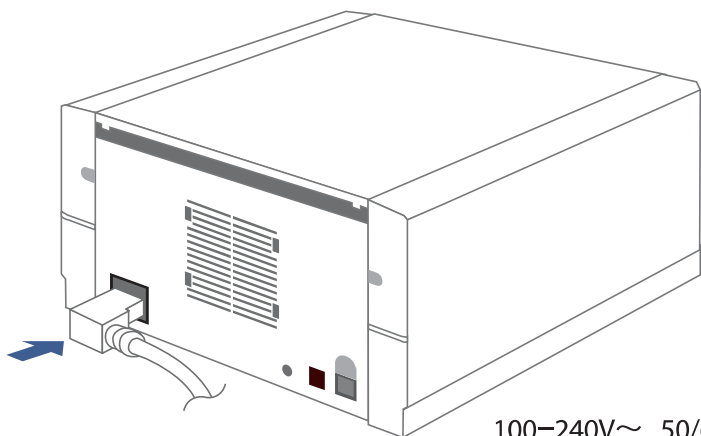

3 Connection with USB cable and PC

Verify that the power switch is turned off then insert the USB cable which is connected PC to USB port.

*Refer to P15 "How to connect with Wi-Fi" , P14 "How to connect with Wired LAN" regarding other connection.

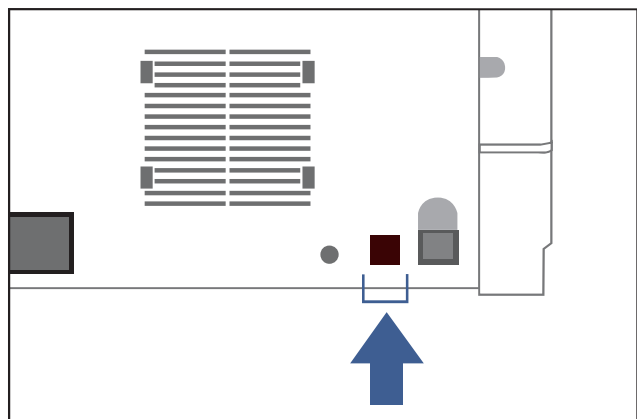

[caution]

*Turn off the power switch before any connecting.

*Connect before turning on.

Chap.4 USB Printer Driver Installation

1 Related Software

The procedure to install addin braille translation software, see “installation manual of add-in software” .

2 Installation procedure for Printer Driver with USB

To print with this machine, the USB driver and the application software for USB driver shall be installed.

Note : in the case of printing braille, see “Installation manual of add-in software.

Supported OS : Windows® 10 (32/64bit)



(1) Power on your personal computer and then insert the attached CD-ROM.



(2) Run one of the following files included in the CD-ROM depending on your PC specifications:

- ① In the case of 64-bit PC : ETXDRV64.msi
- ② In the case of 32-bit PC : ETXDRV.msi



(3) click “Next” .

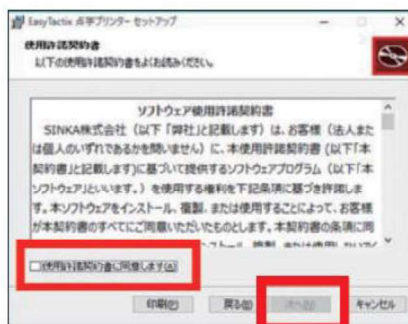

(4) Review the license agreement and, if you agree, check the “I accept the terms of the license agreement” then select “Next” to continue.

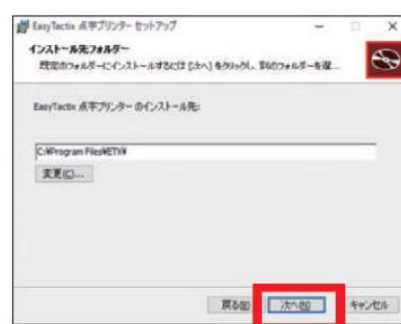

(5) Confirm the folder to be installed then click “Next” .

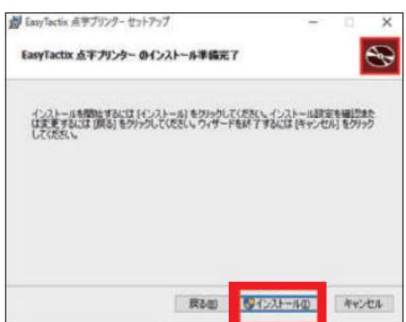

(6) The PC is ready for installation. Check the “installation” button then install the software according to the guidance on the screen.



(7) The setup wizard has been completed. Click the “Finish” button to quit.

Follow below procedure for connecting printer with USB cable.

* See operation manual for installing driver when you use Wi-fi or LAN cable.

3 Installation Printer Driver with USB

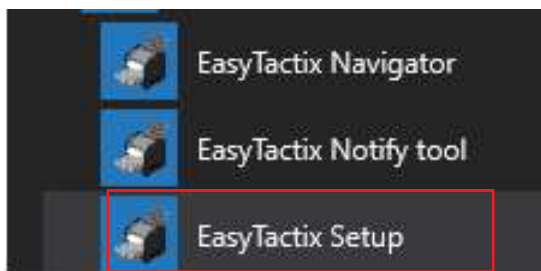

(1) click "set up" from Start menu.

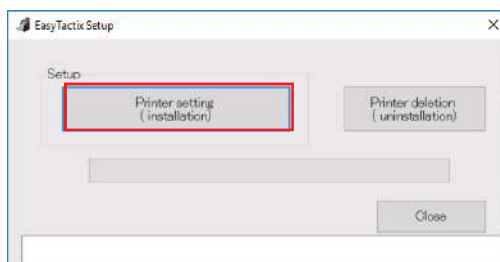

(2) click "Printer setting" .

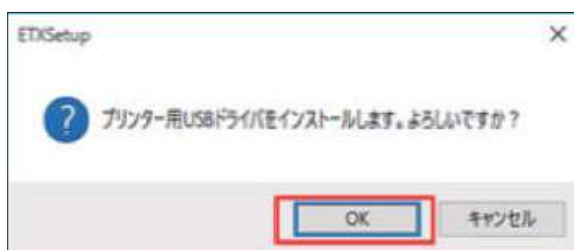

(3) click "OK" .



(4) close all the software, then click "reboot" .

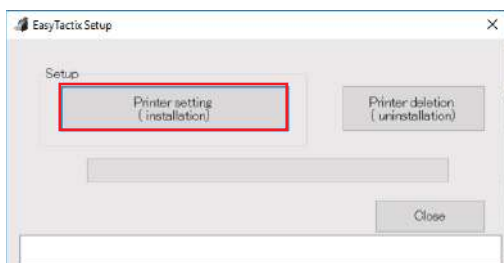

(5) after rebooting, this window automatically appears, click "printer setting"



(6) click "OK" .

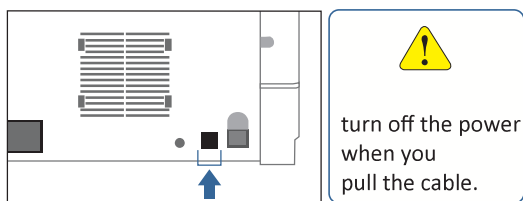

(9) connect machine and USB cable then turn on the power.



(8) click "OK" for installing Printer.



(9) click "Install" .

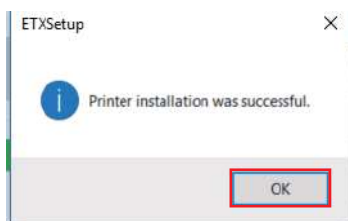

(10) click "OK" .

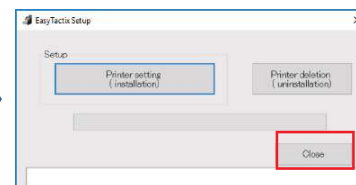

(11) click "close" .

*When you cannot success to install driver, follow the step next page.

4 Uninstallation of Printer Driver

To uninstall Driver, “Delete the driver” and “Delete setup application” are needed.

Operation Manual

● Delete the driver

(1) From the start menu, click “EasyTactix Uninstaller” in folder.

●Windows10

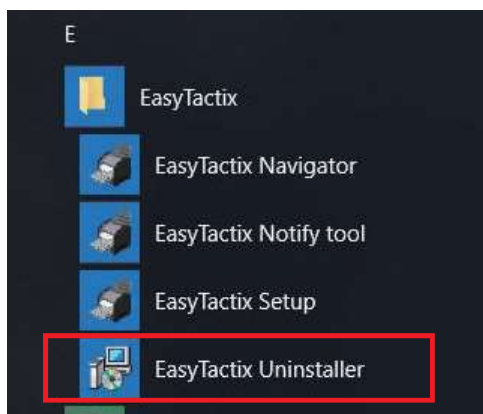

(2) click “uninstall” .

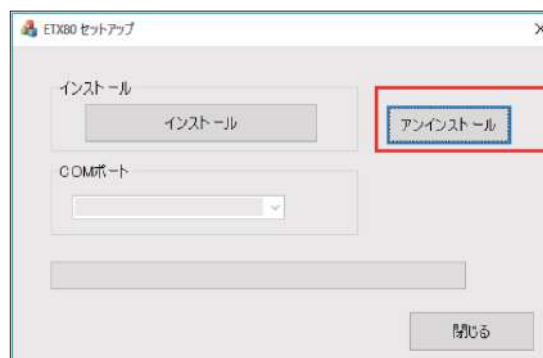

(3) click “OK” .



(4) click “OK” .



(5) To finish the uninstallation, reboot Windows and follow the step “Delete application” in the next page.

5 Delete setup application

(1) From the start menu, click “setting” and activate app.
Then, click “system” .

● For Windows10



(2) From the “Apps & features” , select EasyTactix.



(3) after opening dialog, click “Uninstall” .



(4) Click “Uninstall” .

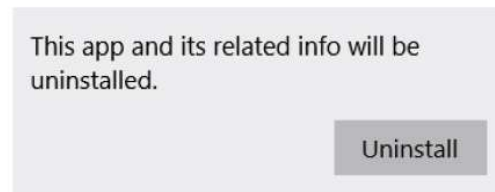

(5) Once progress bar is closed, uninstallation is finished.

Chap.5 How to connect with Wired LAN/Wi-Fi

1 How to connect with Wired LAN

* For connecting with USB cable, follow the step “ch3 How to connect” .



■ limitation of interface

Please connect with one interface from Wired LAN/ Wi-Fi/USB interface. the printer is not supported multi interface connection.

<Preparation>

Install application of USB printer driver(P.10) with USB mode beforehand.
And connect between printer and USB cable.

(1) Open Easytactix folder,
and click “EasyTactix Navigator”

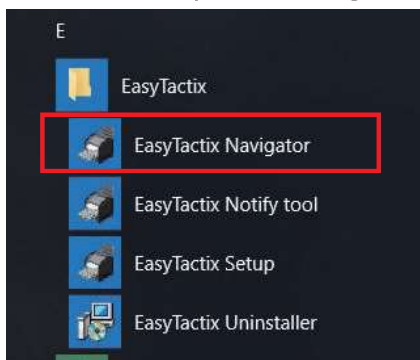

(2) Select “Wired LAN” from the menu.



● Using DHCP (Dynamic Host Configuraton Protocol)

(3) Select “Use DHC” in “3.IP address acquisition method” field.
Then click “8. Connection(Printer IP setting)” .

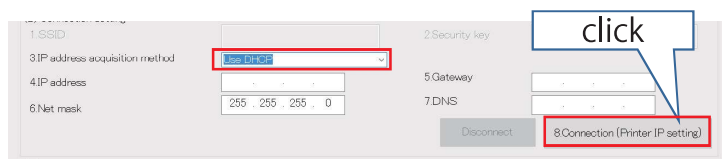

After few seconds, the answer will be returned that connection was successful or not.
if failed, contact to network administrator.

● Using IP address

(4) Select “Manually set static IP address” in “3.IP address acquisition method” field.
Then type static IP address, net mask, gateway, DNS etc.
Once everything is finished, click “8.Connection(Printer IP setting)”

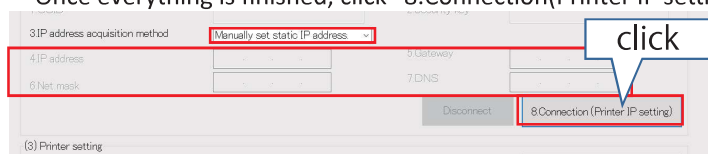

After few seconds, the answer will be returned that connection was successful or not.
if failed, contact to network administrator.

(5) Follow the step “③Add Wi-Fi mode ” for both connection.

② How to connect with Wi-Fi

* For connecting with USB cable, follow the step “ch3 How to connect” .



limitation of interface
Please connect with one interface from Wired LAN/ Wi-Fi/USB interface. the printer is not supported multi interface connection.

NOTE for Wi-Fi connection
Normally printer will automatically connect through Wi-Fi but when Wi-Fi is not connected because of radio wave state, (Blue light is not lit) turn off/on the printer and check Wi-Fi is working properly.(Blue light will be lit)

<Preparation>

Install application of USB printer driver(P.10) with USB mode beforehand.

And connect between printer and USB cable.

- (1) Open Easytactix folder,
and click “EasyTactix Navigator”

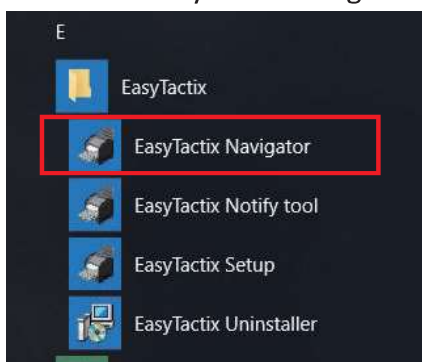

- (2) Select “ Wi-Fi ” from the menu.

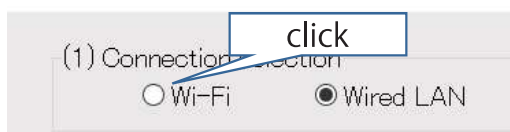

- (2) int the “HOST ” , connectable Wi-Fi host will be displayed. if it is not appeared after a while, confirm the connection with printer and click “seach” .

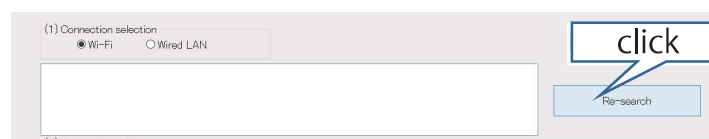

●Select Wi-Fi (Using DHCP<Dynamic Host Configuraton Protocol>)

(4) When using static IP address, follow the step (8).
 Select SSID of Wi-Fi router which you want to use.
 *SSID is written on router itself or manual of router.
 or contact network administrator.

(5) put "Security Key" which is written on router or manual,
 or ask network administrator.
 The way to get IP address is to select "Use DHCP" .
 After choosing, click "8.Connection(Printer IP setting)" .

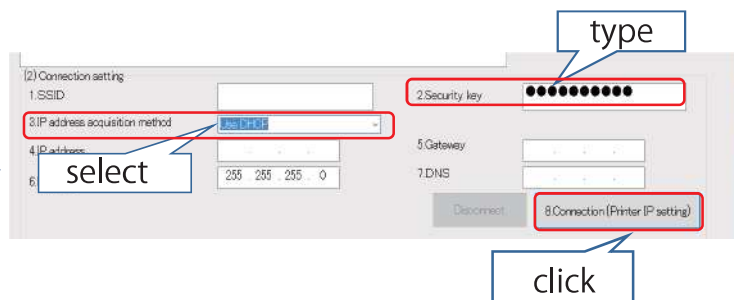
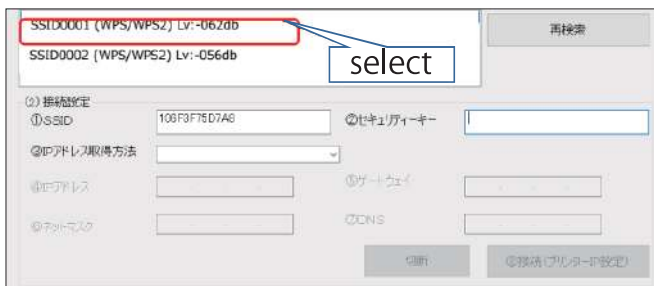

(6)After few seconds, the answer will be returned
 that connection was successful or not.
 if it failed, check the security key and try again.
 if it still fail, contact to network administrator.

(7)If it succeeded, the value of printer when setting
 the driver will be displayed in the field of
 "statisic IP address" . Port name will be set
 automatically.when you want to change IP address
 you can also use this field.

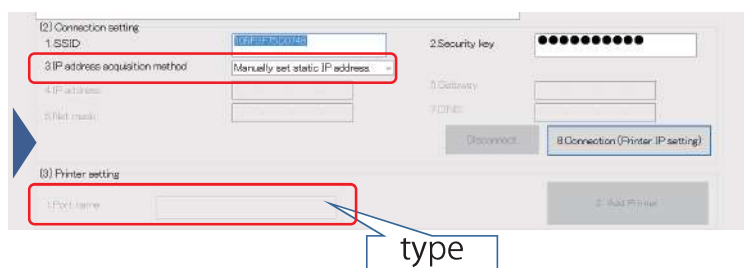

* If you want to add PC connecting with printer,
 follow the step "D. Add second Printer" .

●Select Wi-Fi (Using static IP address)



After few seconds, the answer will be returned
 that connection was successful or not.
 if failed, check the security key you typed,
 and try again.
 If still failed, contact network administrator.

Then follow the step "③Add Wi-Fi mode" .

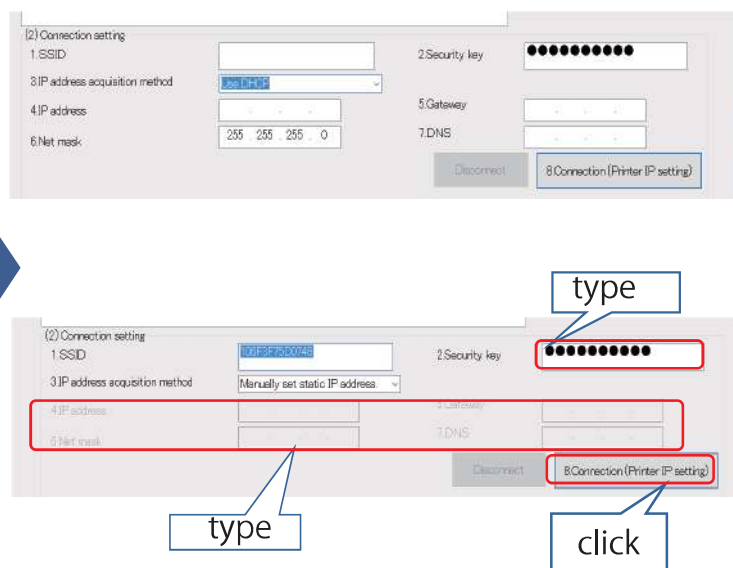

3 Add Wi-Fi mode

(1) Click “Add printer”



(2) when finishing job, click “close” .

(3) Open “devices and printers” from control panel.
and check “Easy Tactix(network)” is added.



Devices

Bluetooth, printers, mouse

If you use windows10, you can also find from setting.
click “devices” and “printer and scanner will be displayed.

Chap.6 Add the second printer

1 Add the second printer

<Preparation>Install application of USB printer driver(P.10) with USB mode beforehand.
Ask network administrator about IP address and keep it.

(1) Open Easytactix folder,
and click "EasyTactix Navigator"

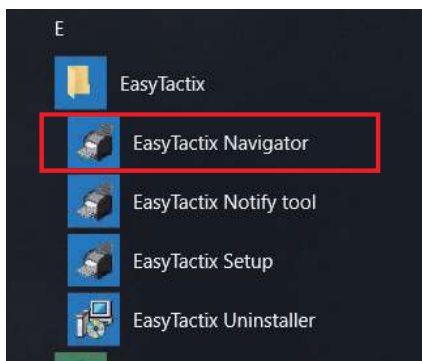

(2) Check "administrator function" .

Administrator function (when connecting the second and subsequent computers).
※Please see the instruction manual for details.

Check

(3)Put IP address of connecting printer
which kept in a memo

(4) Put "port name" in the field.
ex: designate same IP address of printer

(5) Follow the step "③Add Wi-Fi mode" (P17)

Chap.7 Set Dedicated Swell paper

1 Set Swell (dedicated) paper

(1) Open top cover and exit tray.

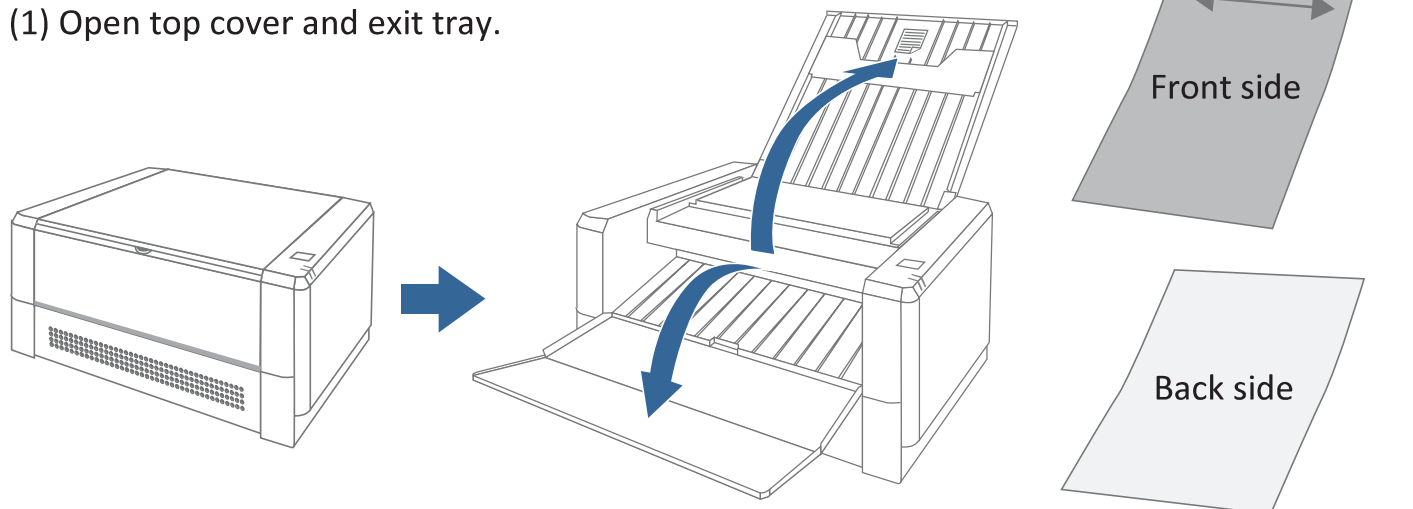

(2) Set the paper to the Paper feed tray as the light gray color will be upper side.

! Smooth texture side will be upper side when you touched the surface.



Note : Please set paper one by one.

【caution】 when closing Paper feed tray, move back Paper feed tray guide to original position.

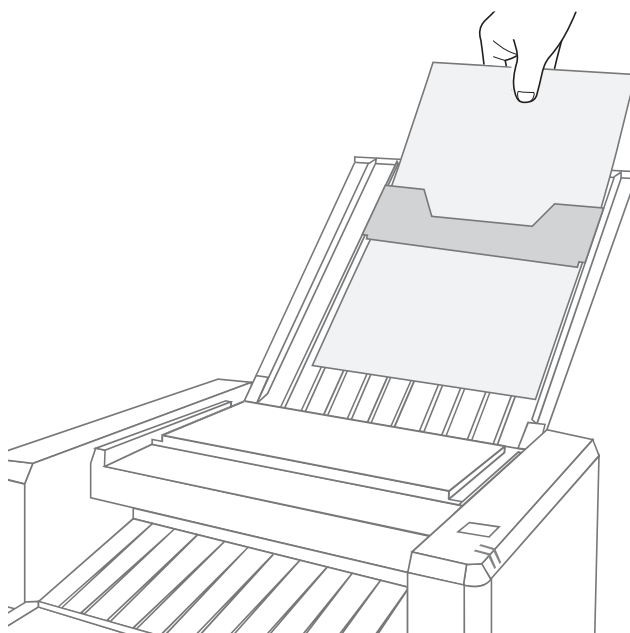

Note : Please use only dedicated swell paper for TactPlus.

【caution】 if other paper is used, it might cause of the problem.

① Printing

① Start the printing

ex : Word Printing

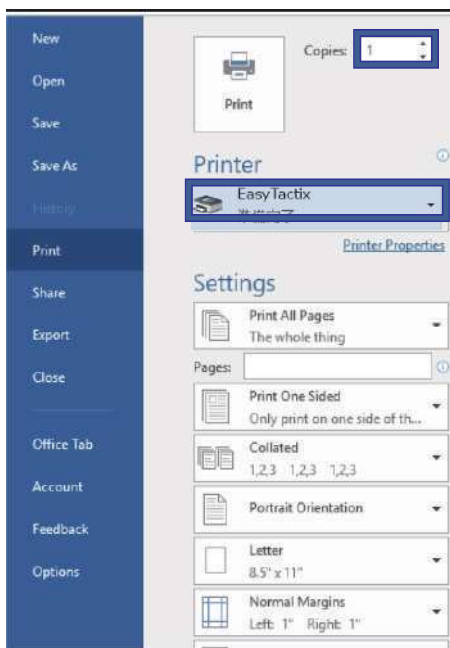

(1) Select “Easy Tactix” from Print menu
Note : The property setting both when printing “only braille” and “braille & graphic”
You can refer to ch9. Printer driver specification (P21).

↓
(2) Click “Print”

② Finish the printing

 **NOTE** :Do not pull out paper when printing, it might cause out of order.
【caution】

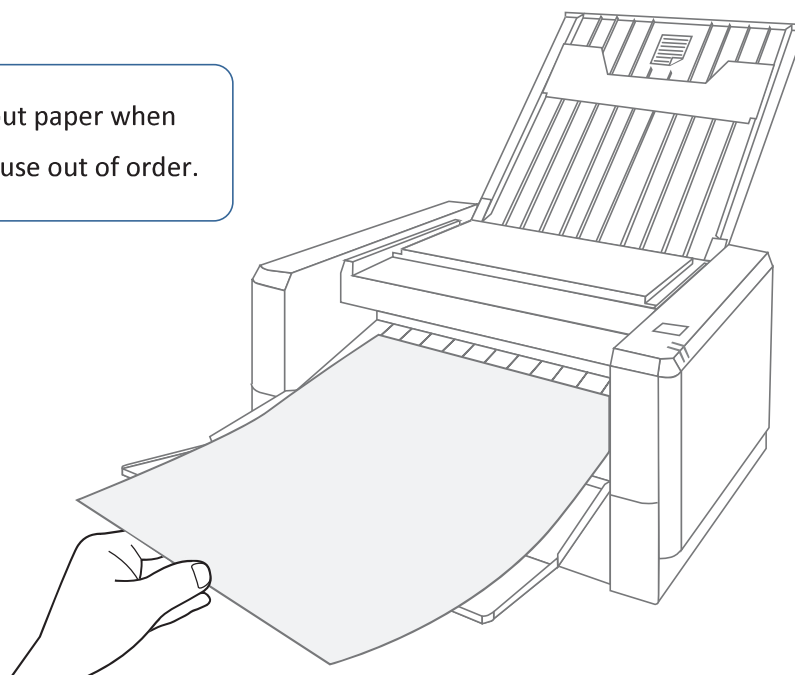

Chap.9 Printer driver Specification

The screen of each printer driver shown below is displayed after specifying "Print Menu" in the software you are using, selecting the printer name "Easy Tactix" in the print menu screen that is displayed after that, and clicking the property. You can check the setting.

(1) This is the first "Document Properties" screen that appears after clicking Properties. The "Layout" tab is selected, and you can set the print orientation and print order.

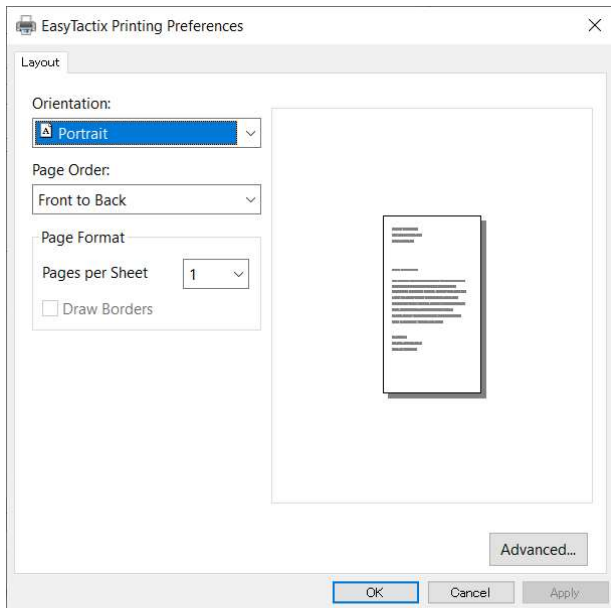

(2) This screen is displayed when you click the "Detailed Settings" button at the bottom right of the document properties.

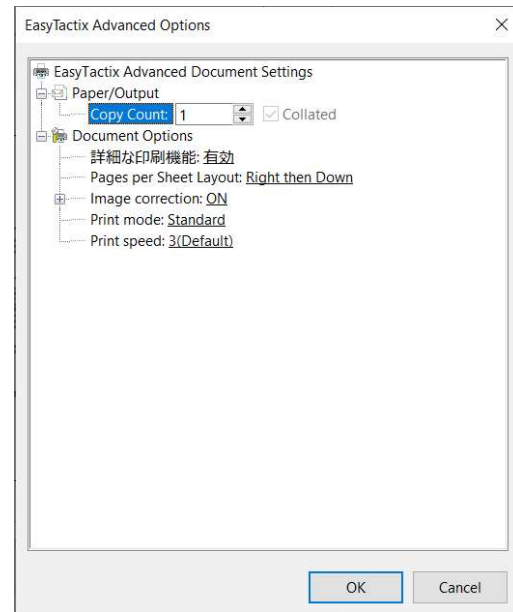

(3) Set enable / disable of image conversion.

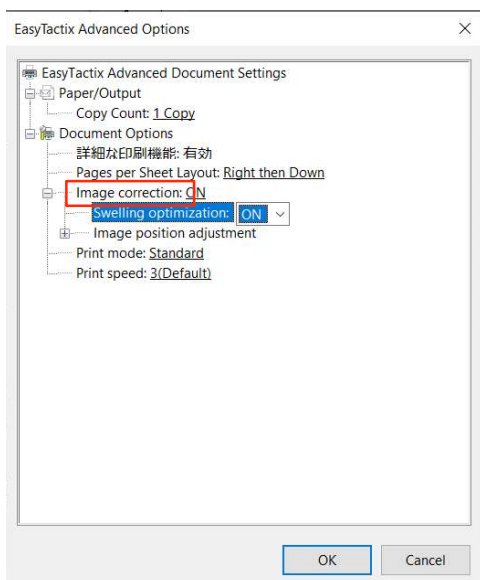

(4) Optimize the height of the tactile.

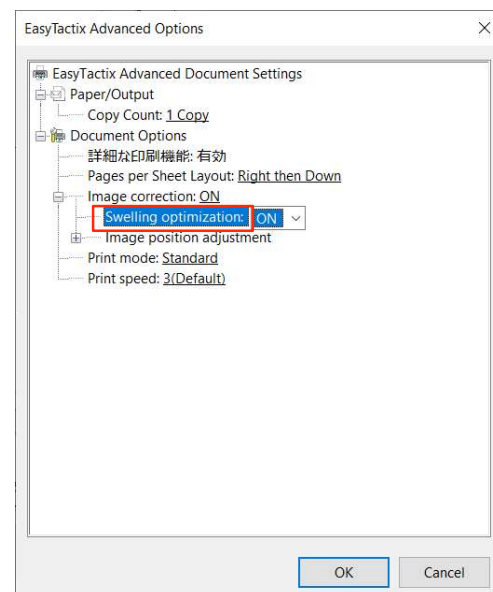

You can adjust the three-dimensional height and the print position / print area.
 ON: Adjustment is enabled.
 OFF: Adjustment is not effective.

ON: Do not perform optimization,
 OFF: Optimizes the height of the solid.
 * If the surface is rough, we recommend ON.

(5) You can adjust the print position and print area.

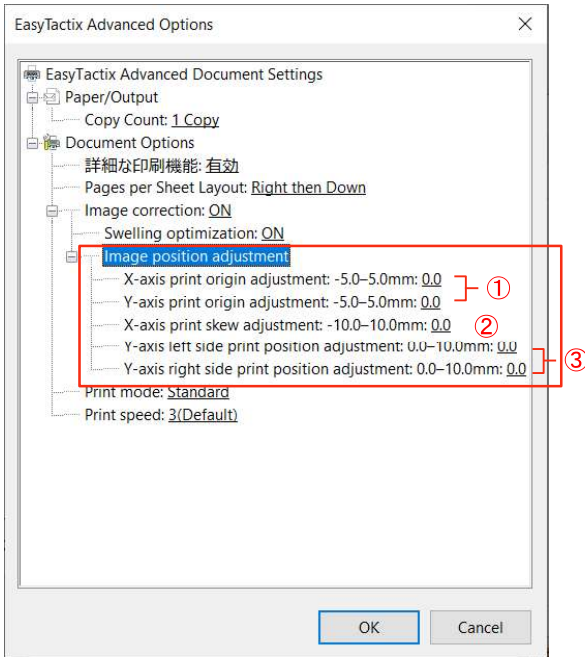

- ① : Start position of print
- ② : Skew
- ③ : length of print

Adjustment method

1. Print the Test chart.PDF file.
 - 1-1 When you want to print a color solid using an inkjet printer
 - ① Print the adjustment pattern (Test chart.PDF) with an inkjet printer.
 - (2) Set the printed paper in TactPlus.
 - ③ Print the adjustment pattern (Test chart.PDF) with TactPlus.
 - 1-2 When not printing a color solid using an inkjet printer
 - (1) Print the adjustment pattern (Test chart.PDF) with TactPlus.
2. See Adjust print position (6).
3. Adjust skew (see (7))
4. Print the Test chart.PDF file.
 - 4-1. When you want to print a color solid using an inkjet printer
 - ① Print the adjustment pattern (Test chart.PDF) with an inkjet printer
 - (2) Set the printed paper in TactPlus.
 - ③ Print the adjustment pattern (Test chart.PDF) with TactPlus.
 - 4-2. When not printing a color solid using an inkjet printer
 - ① Print the adjustment pattern (Test chart.PDF) with TactPlus
5. See Adjust print length (8).

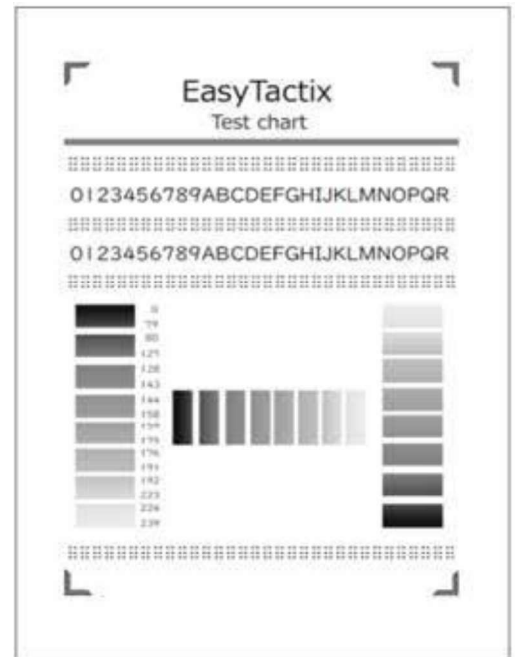

(6) You can adjust printing position.

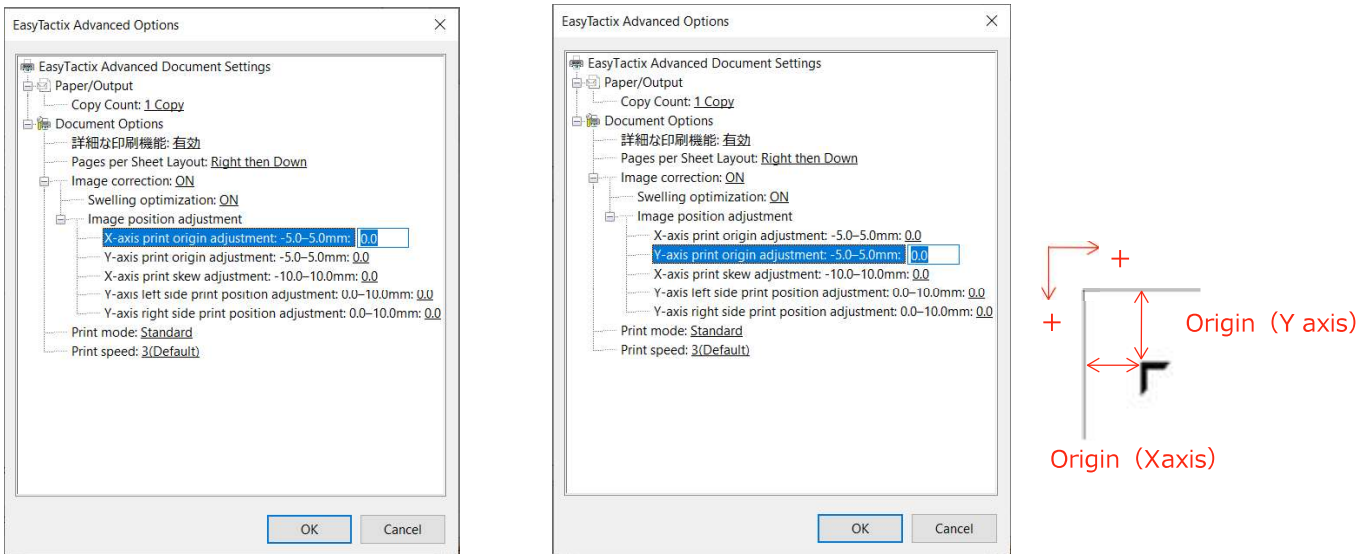

When you want to print a color solid using an inkjet printer

Enter the difference from the inkjet printer at the origin (X, Y)

In that case, if you want to move the output result of TactPlus downward, it will be a positive value.

If you do not print a color solid using an inkjet printer, origin(X) : Adjusted Value = 21.5-measured value

Origin(Y) : Adjusted Value = 25-measured value

(7) You can adjust Skew.

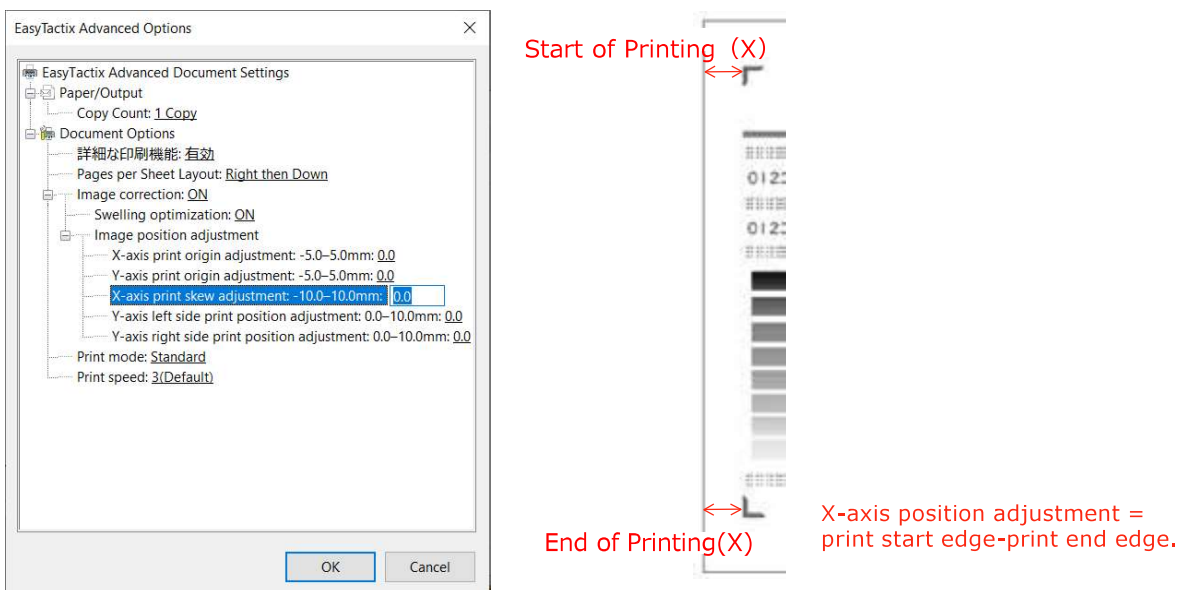

When you want to print a color solid using an inkjet printer

Please measure the output result of TactPlus. At that time, if the inkjet printer is shielded from light, adjust it with the inkjet printer.

If you do not print color solids with an inkjet printer, measure the output of TactPlus.

(8) You can adjust the length when printing.

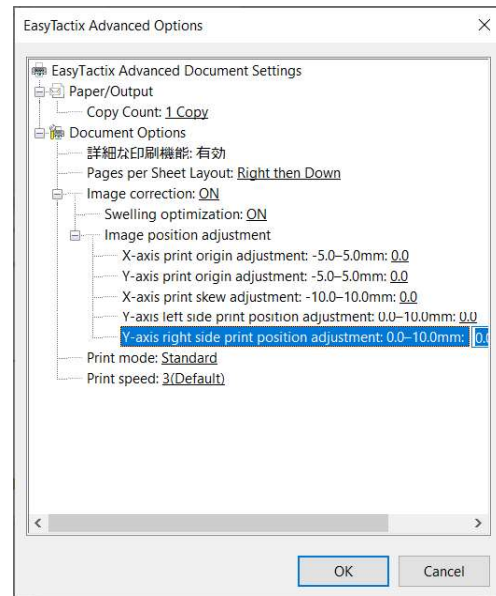
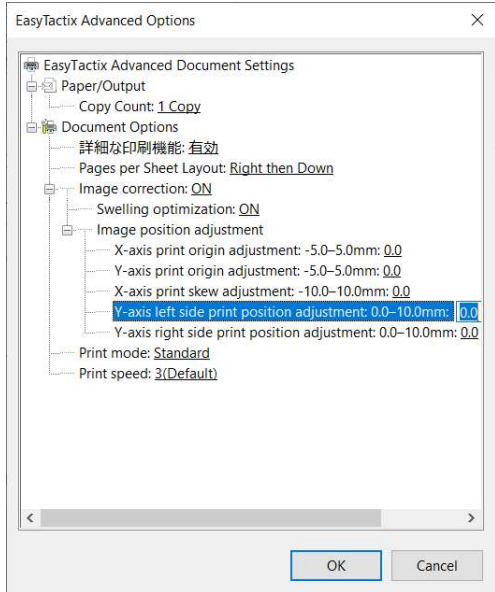

■ When you want to print a color by using an inkjet printer

For Y-axis adjustment (left edge / right edge), enter the difference from the inkjet printer. In that case, if you want to move the output result of TactPlus downward, it will be a positive value.

If you do not print a color solid using an inkjet printer, Y-axis adjustment (left edge / right edge) = 30-Please enter the measured value

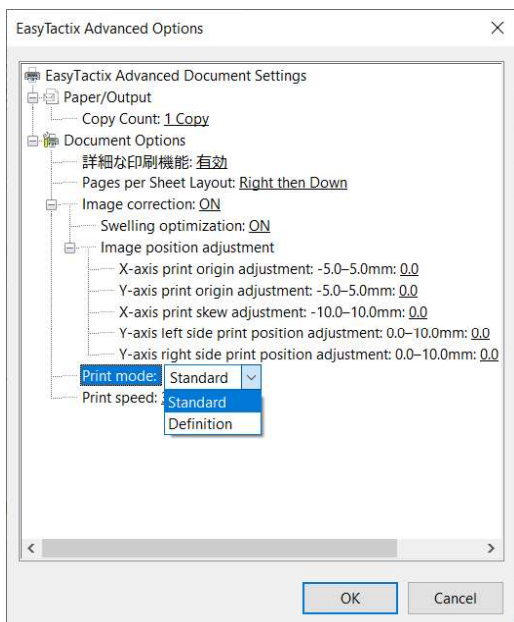

(8) You can select printing mode.

Standard: Outputs well-balanced small figures such as Braille and large figures such as maps.

Fine : Suitable for outputting a portion of low height (data with low input density).

(10) Select print speed

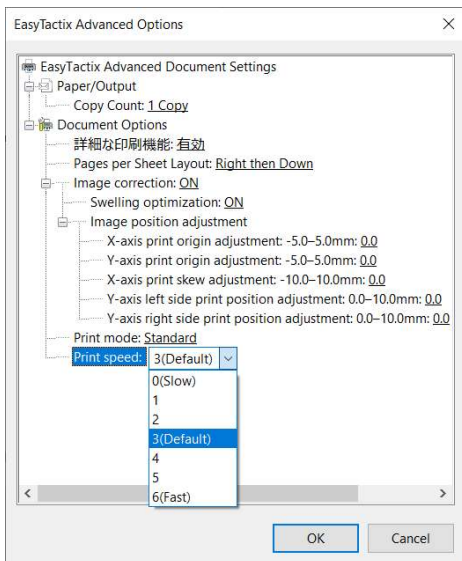

By changing the print speed, you can change the height of the entire tactile. (0: slow[high] – 6: fast[low])

● How to open Properties

Follow the step below for opening Printer Properties.

※Windows10

(1) click “” .

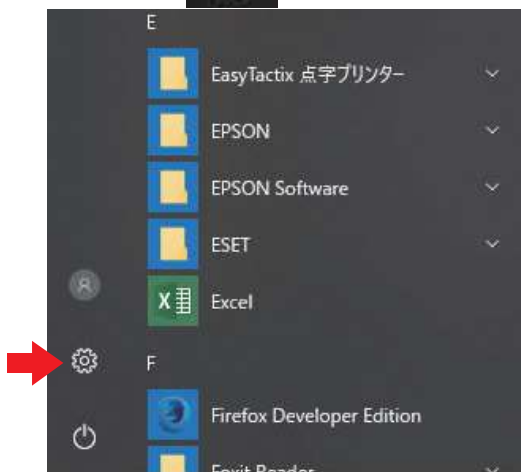

(2) click “Devices” .

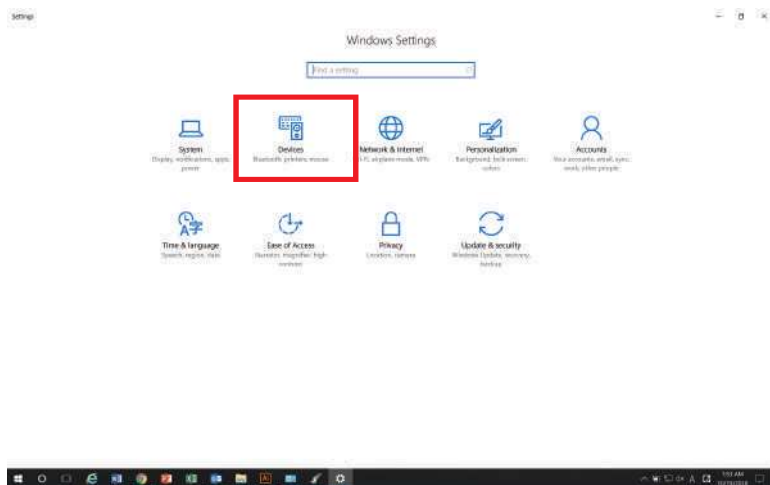

(3) click “Printers & Scanners” .

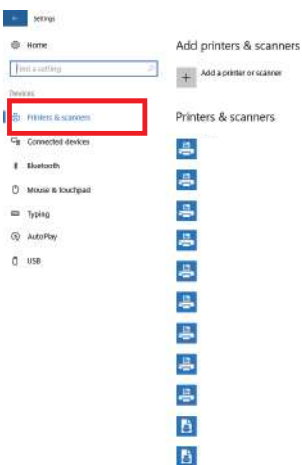

(4) Select “EasyTactix” and click “Manage” .



(5) Click “Printer Properties” .

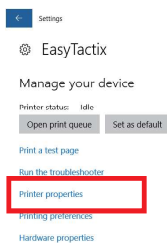

(6) Click “Preferences...” .
Then move to the screen (1) in P21.
Follow the step from page above.

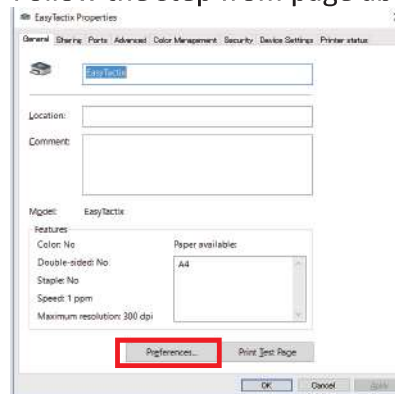

Voice Guidance

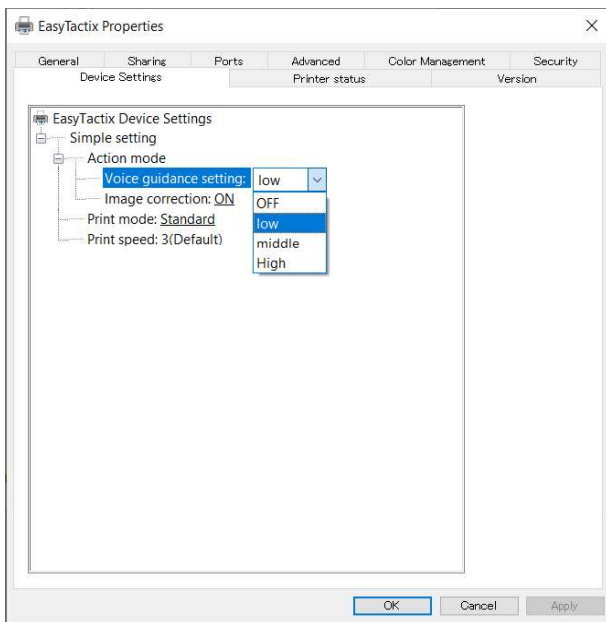

Using “Voice Guidance” , you can choose volume OFF(silent)/Small/middle/ Big.

■ Properties> Device Settings>

Chap.10 Voice Guidance and Message on display

This printer has “Sound Guidance function” and Message on Display function”
 Regarding sound volume adjustment, follow the step (5) in Ch.9 Printer Driver Specification.
 See the list of “Sound Guidance” and “Message on Display” . And follow “Counter measure” when problem happened.

Sound Guidance	Message on display	Status	Counter measure
Power switch turned on.		Turning on	
Ready to print.		Ready for printing	
Now printing.		Printing	
Finished printing.		Printing is finished	
Paper empty. Set paper and press the operation button.		Paper is not set	Set dedicated paper in the paper feeder.
Paper has not reached the transport section. Long press the operation button, Paper will be forced out to the output tray.		Paper jam	Push operation button for a while and start ejection.
Paper is not properly transported. Long Press the operation button, Paper will be forced out to output tray.		Paper was fed as the paper is tilt	Push operation button for a while and start ejection.
Papers overlapping. Long Press the operation button, Paper will be forced out to the output tray.		Double feeded	Push operation button for a while and start ejection.
Paper jammed. Long Press the operation button, Paper will be forced out to the output tray.		Paper jam	Push operation button for a while and start ejection.
Paper Force to output tray has started.		Eject paper forcibly	
Paper Force to output tray has completed		Finish paper ejection	
Paper remains in the transport section. Turn off the power and remove the paper in the input and output tray.		Paper jam	If paper is not ejected after pushing button, follow below step. (a) If you can grab paper from ejection side, pull it out slowly not to tear. (b) If you still cannot pull out, call the service center.

Sound Guidance	Message on display	Status	Counter measure
Ready to resume printing. Set paper and press operation panel.		Printer is recovered and can print again	Set the paper and push the operation button.
You have attained your maximum printing count Please contact your vendor	The roller is at the end of its life.	Roller has problem	Set the paper and push the operation button.
Thermal head failed Please contact your vendor	Print head is defective	Print head has problem	Call the service center.
Paper feed motor failed Please contact your vendor	The motor is out of order.	PM motor has problem	Call the service center.
Preparing to print Please hold		Preparing for printing	Call the service center.
Preparing to print Please hold		Status which TPH exceeded proper value. once TPH cool down, automatically recover original status.	
System will now update the firmware. Do not turn off the system during the update, as it may cause the system to fail		Firmware auto updating	Wait for a moment without turning off until you hear the sound "version up is finished"
Firmware update complete. System will automatically restart.		Firmware updating is done	Turn off the printer.
	A fan error has been detected	Fan has problem	Call the service center.
	The temperature of the operation panel is abnormal.	operation panel has problem	Call the service center.

Chap.11 Power/ Message Lamp

Two LED lamps which installed right side show Printer Status.
Regarding detailed status by each color, see below list.

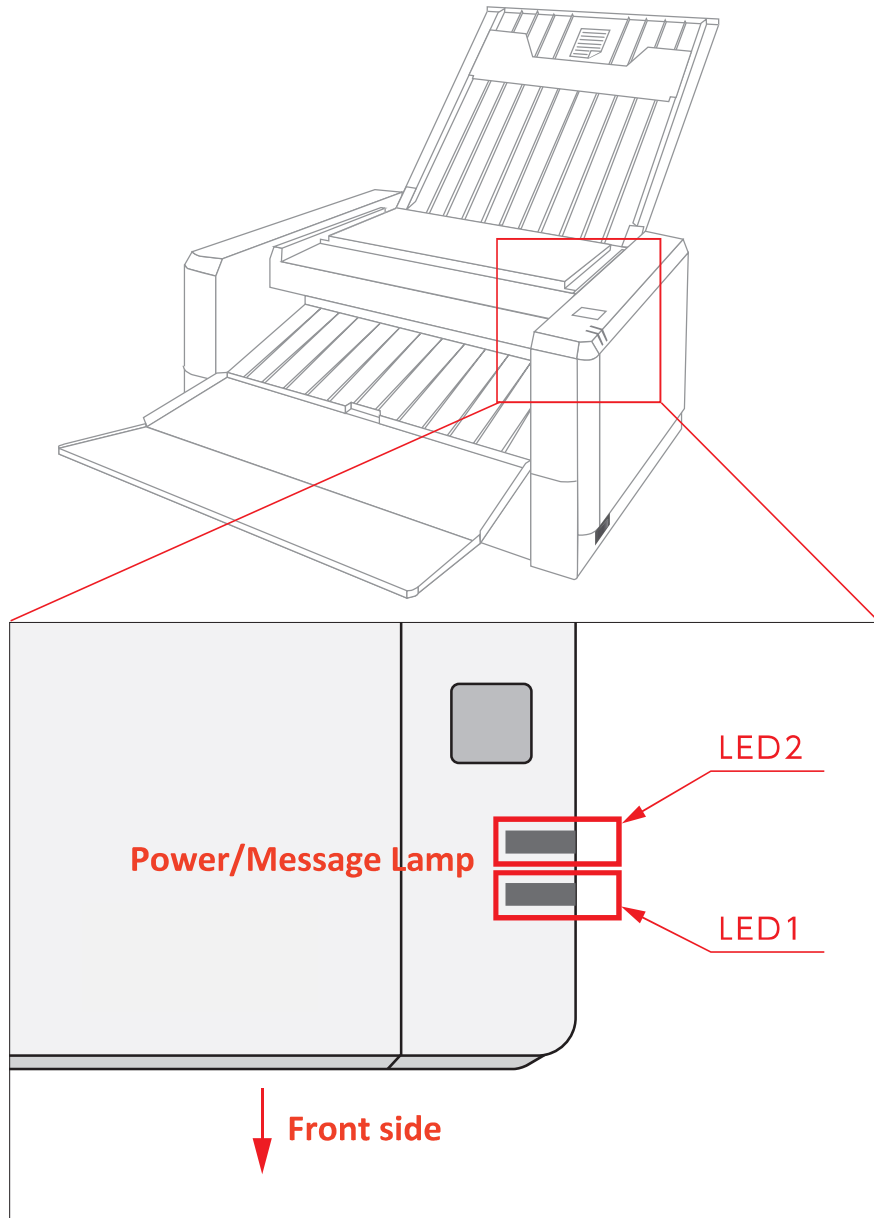

LED1	LED2	
Green/ Blinking	-	Prepare for Printing or Printing
Green/ Light	-	Printer is ready
	Blue/ Blinking	Connecting Wired LAN/Wi-Fi
	Blue / Light	Stand by Wired LAN/Wi-Fi
Red/ Blinking	Red / Blinking	Recoverable error
Red/ Light	-	Not recoverable error

1. Printer is not turned on.

Check power cable is connected with printer and outlet properly.

If cable is connected properly but it is not turned on, call the service center.

2. Printer is working, but Print preparation is not completed.

When printer shows message from “Voice Guidance or Message on screen” , or “Power/Message Lamp” is shown, follow the step ch10.

If problem still cannot be solved, call the service center.

3. Printer is ready, but print won’ t start after sending data.

(1) check Printer “EasyTactix” is selected before printing.

(2) See LED lamps(Power/Message Lamp) status have no problem.

(3) If printer driver is not installed properly, uninstall the driver and install again.

(4) If there is no solution from (1) to (3), or not be solved, contact the service center.

4. Printer is working, but paper is not foamed.

(1) Check using dedicated paper. Do not use other paper.

(2) Follow the step Ch.9 “Printer Driver Specification” .

(3) Check the setting and if still cannot be solved, contact the service center.

5. Paper is foamed, but too low/tall/ rough.

(1) Check using dedicated paper. Do not use other paper.

(2) Follow the step Ch.9 “Printer Driver Specification” .

(3) Check the setting and if still cannot be solved, contact the service center.

6. would like to adjust volume of Voice Guidance.

Refer to Ch.9 “Printer Driver Specification” .

* You can set OFF(silent)/Small/Middle/Big.

When you still cannot adjust the volume, contact the service center.

7. Paper is jammed.

(1) Press operation button for more than three seconds and check paper is fed out.

(2) If paper is remain in the printer and cannot take it out, contact the service center.

8. Paper is not fed properly.

- (1) Check the paper is set only one to supplying tray without tilting.
- (2) Check the paper is dedicated paper. You cannot use other paper.
- (3) If “Voice Guidance” , “message on screen” or Power/message Lamp are shown abnormality, follow the step Ch.10.
- (4) if there is no solution above, call the service center.

9. Other troubles

- (1) When connecting multi option components, you may feel electricity sometimes.
in such case, ground from printer or optional components or PC etc.
When using this printer, do not use conversion plug and
recommend to use three necked plug(with ground terminal)
- (2) In FAQ, Ch.10, or Power/message Lamp,if there is no solution or do not know the countermeasure or trouble cannot be solved, call the service center.

Chap.13 Product Specification

■ Product specification

Printing method	Thermal Printing with 300 dpi
Print speed	100 ~ 150 seconds (in printing Braille 22 lines)
Thermal Print Head	300 DPI
Supply & Exit Tray	1 paper each
Interface	USB2.0 / Wi-fi (Wireless LAN)/100Base-T/TX (Wired LAN)
Electric characteristics	AC100-240V 50/60/220W (IN PRINTING)
Supporting OS	Windows 7/8.1/10 (32/64bit)
Supporting Driver	Dedicated Driver
Voice Guidance	○
Size(WxDxH:mm)	(unused) 316x286x164 (used) 316x637x340
Weight (kg)	4.9
Temperature(°C)	10 ~ 30
Operational humidity(%RH)	35 ~ 70 (Non-condensing)
Emmission value	under 50db
Warranty	1 year
Media	Dedicated Paper(A4 size : 8.27" x 11.69")

■ safety regulation cULus / CE / FCC

This equipment must be earthed. The power plug must be connected to a properly wired earth ground socket outlet. An improperly wired socket outlet could place hazardous voltages on accessible metal parts. Note' This equipment has been tested and found to comply with the limits for a Class A digital device, pursuant to part 15 of the FCC Rules. These limits are designed to provide reasonable protection against harmful interference when the equipment is operated in a commercial environment. This equipment generates,, uses, and can radiate radiointerference to radio communications.

Operation of this equipment in a residential area is likely to cause harmful interference in which case the user will be required to correct the interference at his own expense.

This dedice contains license-exempt transmitier(s)/receiver(s)that comply with Innovation, Science and Economic Development Canada' s license-exempt RSS(s). Operation is subject to the following two conditions;

1. This device may not cause interference.
2. This device must accept any interference, including interference that may cause undesired operation of the device.

This eqipment complies with IC RSS-102 radiation exposure limits set forth for an uncontrolled environment.

This equipment should be installed and operated with minimum distancce 20 cm between the radiator & your body.

Chap.14 Registered Trade mark & Description

*All named products and descriptions in this manual are trademarks and/or registered trademarks of

the respective manufacturers and are accepted as protected.

*Microsoft, Windows Aero, Windows Live, Access, Word, Excel, Word logo, Excel logo, Office logo, OneNote, Outlook PowerPoint, Windows Media, Windows logo, Windows start logo are the registered trademark of the Microsoft Corporation in US or related company.

*TactPlus. is the registered trademark of the Kanematsu Corporation.

Chap.15 Service support/Purchase of dedicated paper/ Manufacture Manual Revision history

■ Service support/ Purchase of dedicated paper

If the product should break or malfunction,
please contact the retail shop where you purchased the product.

■ Inquiry

Manufacturer : SINKA Corporation

The selling agency : Kanematsu Corporation

<https://www.tactplusprinter.com/>

Chap.16 Operation Manual Revision history

Revision	Date	Page	Content
1.00	August,2018	All	New
1.10	September,2019	10-13,21-27,29,33	Add/Revise